

PENTABLOCK™ Technical Information

160mm Series

The PENTABLOCK™ Walling System was developed in consultation with masonry construction stakeholders with an aim of reducing labor time and material costs required for concrete masonry walling. The PENTABLOCK™ Walling System is designed in accordance with AS3600 Concrete Structures and AS3700 Masonry Structures. The PENTABLOCK™ Walling System can be used for all applications in the residential, civil and commercial construction industry's including structural façade walls, retaining walls, free standing fences and fence pillars, basement construction, multi-story construction, garden features, tanks, swimming pools and more. This type of walling system is superior to other conventional construction methods due to its unique concrete interlocking rebate system, which eliminates the need for formwork and mortar, whilst providing high structural integrity when filled with concrete and steel.

The biggest advantage of the PENTABLOCK™ system is the productivity gains that are delivered to builders, installers and other trades with the addition of cost savings and increased strength and capacity's compared to conventional methods.



1300 3 PENTA | 1300 3 73682

Visit our website: www.pentablock.com.au

E-mail us: info@pentablock.com.au

Preliminary

- Excavate to a satisfactory foundation depth.
- Form the base to the required dimensions and levels as shown in details or plans.
- Place the foundation steel reinforcement as shown in the diagrams or specified in the drawings.
- Pour the foundation including vibrating of concrete if specified. Wood float finish is recommended taking care not to dislodge reinforcement.

Note: First reinforcement bar is placed at 80mm from the end (to avoid cross web).

Block laying

- Normal Block laying practices are adopted but there is no requirement for mortar and units are simply stacked on top of each other in a brick bond pattern maximising freestanding strength and stability. There are 18.5 blocks per square meter Note: The first course should be bedded in mortar to provide stability and maintain alignment.

-The blocks are laid with the rebate section of the block to the outside. It is important to keep the rebate section of all block work free of debris to maintain vertical alignment. In the event that a joint is visibly open, the block should be removed and the debris removed. Vertical alignment should be checked at regular intervals

Note: Small plastic wedges can be used under blocks to achieve vertical alignment if required and removed when concrete fill has cured.

-The concrete foundation should be level in preparation of first course of block work and a builder's string line and level will be required to keep the wall aligned vertically and horizontally. In instances where the wall is accidentally laid out of line, or movement has occurred adjustments can be made by using a piece of wood and a heavy hammer to knock the wall back into alignment.

-Reinforcement for wall cavities must be positioned in accordance with specifications and tied securely before placing concrete. Vertical reinforcing bars shall be placed as specified and bars shall overlap a minimum of 600mm.

Drainage and Tanking

- In some applications tanking of the back of PENTABLOCK™ walling system can be avoided if the continuation of the single internal cavity is maintained and that the filling used is a certified waterproofed grout or is a 40mpa + concrete mix.
- As with all retaining walls, it is critical that the backfill is prevented from becoming saturated. Steps to be taken to achieve this include:
 - A drainage system behind the walling should preferably take the form of a 300mm width of gravel immediately behind the wall from top to bottom with a slotted PVC pipe and geo fabric liner located at the base of the wall diverting all ground water to a legal storm water point.

Bracing

- The galvanized steel webbing within the PENTABLOCK™ system can be fixed to vertical steel reinforcement bar strengthening the overall construction and assisting the potential bracing requirements.
- We recommend a maximum lift and core fill without the use bracing of 1.5mt high.
- During grouting of PENTABLOCK™ walls above 1.5mt, it is recommended that suitable bracing should be used to support the wall.
- Temporary bracing of partially built PENTABLOCK™ walls above 1.5mt is also recommended and especially during windy conditions.
- We recommend a lift and cavity fill without the use bracing should not exceed a height of 1.5mt.
- Bracing for Columns is not required

Grouting

PENTABLOCK™ system provides a continuously open cavity allowing for adequate flow while filling grout and ensuring complete coverage of reinforcing steel bars. As PENTABLOCK™ requires no mortar above the first course, there are no mortar dags on the steel or on the inside of the block cavity, eliminating any chance of voids in the wall and substantially increasing the capacity and strength of the structure. The grout will bond together adjacent blocks, block webbing and bond steel reinforcement unifying the wall into a single structure.

- Minimum grout requirement is 20mpa.
- For external applications in near-coastal zones (between 1km and 50km from coast), the minimum strength grade should be 25MPa.
- For external applications less than 1km from the coast, the minimum strength grade should be 32MPa.

NOTE: specialist applications or more severe environments an engineer should be consulted.

- Maximum aggregate size shall be 10mm. The grout shall be free of contaminating lumps larger than 15mm (this may require a screen over the pump hopper).

When pumped down into the PENTABLOCK™ cavity, the concrete supplier should use a high-quality super plasticiser to achieve the flow characteristics required.

- Due to hydrostatic pressure build up by the concrete cavity-fill, a maximum filling height between pours of 1.2m high is strongly recommended.

190mm SERIES

1m³ of grout will fill approximately
7.2m² of wall
No. of blocks per m³ of grout 133 blocks

160mm SERIES

1m³ of grout will fill approximately
10m² of wall
No. of blocks per m³ of grout 185 blocks

1. Structural Façade Walls

The PENTABLOCK™ Walling System provides an efficient, strong, cost effective and aesthetically attractive alternative to the traditional brick veneer façade. This type of masonry system is considered a structural facade as the unit cavities are filled with concrete grout and further reinforced with steel bars. The fire-resistance period for this type of walling system is 180 mins and satisfies structural, insulation and integrity requirements. With a variety of natural stone and cladding options available to choose from, this type of external façade system is visually versatile and ultimately structurally sound.

2. Retaining Walls

The PENTABLOCK™ Walling System can be used to construct various earth-retaining structures due to its rigid interlocking system and hollow cross-section, which both contribute to significant material and labour reductions in comparison to conventional block work construction practices. With an innovative unit rebate joint and mortar-less laying, the construction process is much quicker and DIY friendly.

3. Free Standing Walls and Piers

The PENTABLOCK™ Walling System can be utilised as a free standing feature wall, fence wall, isolated pier or alternatively serve as an earth retaining structure on a property site boundary. Since this type of walling system is structural, there is a wide range of options to meet all structural and aesthetic requirements.

4. Basement & Multi-storey Construction

The PENTABLOCK™ Walling System provides an alternative to conventional concrete precast panel design for basements and multistory construction. The steel reinforcement and concrete grout filled cores provide increased bending and axial capacity performance as a walling system and can be designed by a qualified engineer to meet both structural and aesthetic requirements. The fire-resistance period for this type of walling system is 180 mins and satisfies structural, insulation and integrity requirements. Furthermore, conventional tanking methods required for basement construction may not be required when adopting a PENTABLOCK™ walling system. The structural performance of the PENTABLOCK™ wall can act as an adequate barrier against moisture thus eliminating the use of conventional waterproofing methods.

5. Lintels & Openings

The PENTABLOCK™ Walling System incorporates lintel solutions without having to source additional structural materials. The PENTABLOCK™ hollow units effectively provide the formwork for a concrete bond beam that can be designed by a qualified engineer to suit various openings and loadings.

6. Miscellaneous Uses

The PENTABLOCK™ Walling System can be used for a wide range of other applications such as: swimming pool construction, underground tanks, steps and stairs, and landscape features. It is recommended to seek professional advice and guidance before commencing any building works.

190mm Series Technical Information is available
upon request by emailing us at
info@pentablock.com.au

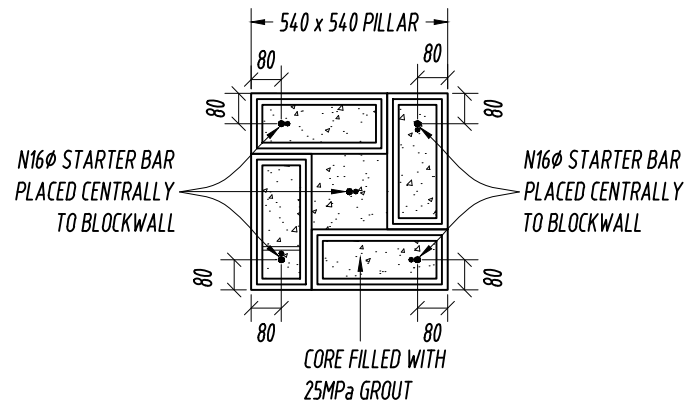
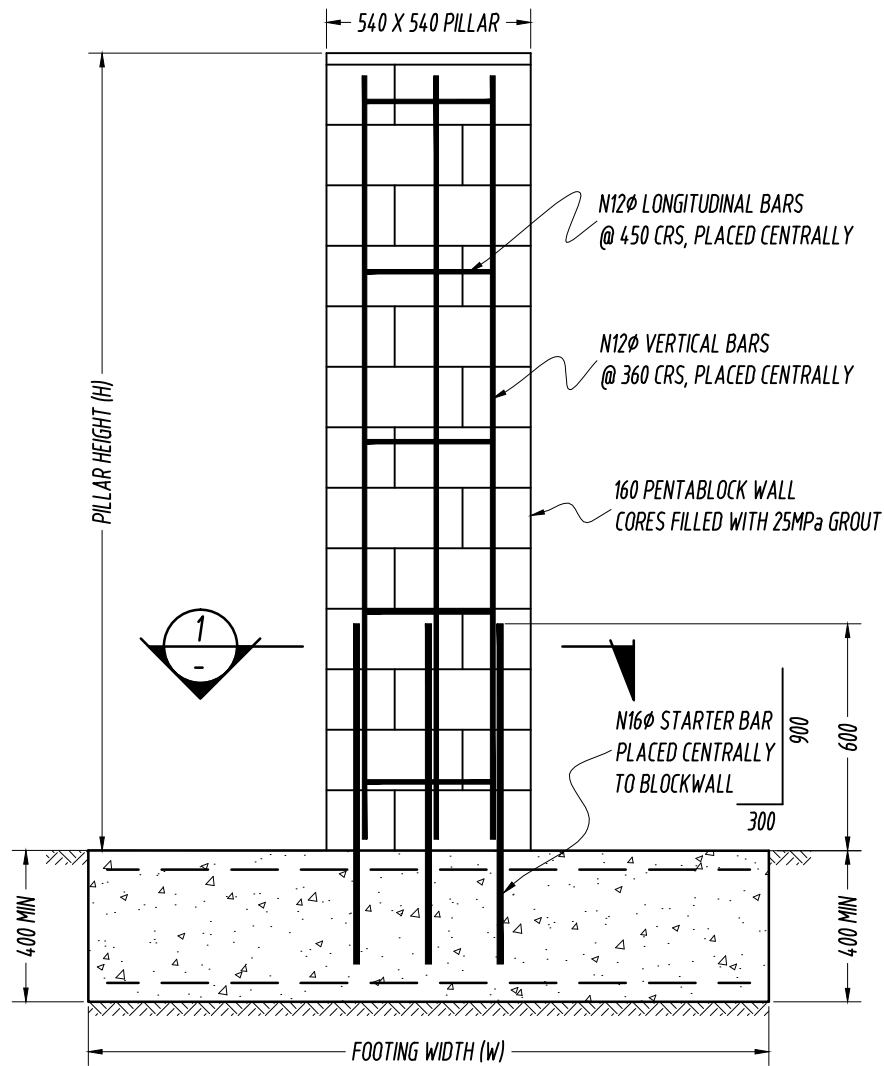

TYPICAL SECTION

SCALE 1:20



160 PENTABLOCK GATE PILLAR SCHEDULE			
PILLAR HEIGHT (H)	GATE POROSITY (% SOLID)	STARTER BARS CRS (S)	FOOTING WIDTH (W)
2500	50	5/N16 ϕ BARS @ 360 CRS	1700 x 1700
2500	75	5/N16 ϕ BARS @ 360 CRS	1800 x 1800

PLEASE NOTE:
 INFORMATION PROVIDED SHOULD BE VIEWED AS A GUIDE ONLY.
 IT IS RECOMMENDED THAT YOU OBTAIN APPROPRIATE PROFESSIONAL
 ADVICE AND DESIGN CERTIFICATION PRIOR TO COMMENCING WORKS.

160 PENTABLOCK GATE PILLAR DESIGN
 HAS BEEN BASED ON A 200 KG GATE WITH
 A MAX SINGLE OPENING SPAN OF 4.5m &
 A VARYING GATE PANEL POROSITY.
 REFER TYPICAL SCHEDULE

PENTABLOCK SYSTEM PROVIDES AN
 ALTERNATIVE SOLUTION TO TRADITIONAL
 REINFORCED BLOCKWORK APPLICATIONS,
 WITH THE BENEFIT OF REDUCED LABOUR
 COSTS, SHORTER CONSTRUCTION TIMES
 AS WELL AS GROUTING & STEEL FIXING
 ADVANTAGES.

FOUNDATION DESIGN IS BASED ON CLASS 'M'
 SOIL CONDITIONS. FOOTINGS TO BE FOUNDED
 100 MIN INTO NATURAL CLAY SOILS,
 MINIMUM BEARING CAPACITY OF 100 kPa.
 MINIMUM CONCRETE STRENGTH OF THE
 FOOTING IS 25 MPa.

CONCRETE GROUT APPLIED TO THE
 160 PENTABLOCK IS TO BE SMOOTH,
 COHESIVE & FREE FLOWING. THE MINIMUM
 STRENGTH TO BE 25 MPa. AS4678 - 2002.

160 PENTABLOCK SYSTEM DESIGN IS BASED
 ON LIMIT STATE DESIGN IN ACCORDANCE
 WITH RELEVANT PARTS OF AS3600-2001,
 AS3700-2001 & AS4678-2002.

160 PENTABLOCK SYSTEM RELIES ON A
 STEEL REINFORCED, CONCRETE FILLED
 160 WIDE PENTABLOCKS CONNECTED TO A
 REINFORCED CONCRETE BASE WITH STEEL
 STARTER BARS TO CREATE A STABLE
 STRUCTURE SUITABLE FOR BUILDING &
 LANDSCAPING APPLICATIONS INCLUDING
 RETAINING WALLS, BRICK PILLARS & FENCES

TYPICAL 160 WIDE PENTABLOCK GATE PILLAR

NTS



CHADWICK GRIMMOND
 CONSULTING ENGINEERS PTY LTD
 Est. 1999
There are no problems, only solutions
 SUITE G, 3/19 BRUCE ST. PHONE: 03 5973 4257 EMAIL: cgcoe@cgcoe.com.au
 MORNINGTON, VIC. 3931 FAX: 03 5973 4258 WEBSITE: www.cgcoe.com.au



PROJECT
PENTABLOCK™ TECHNICAL BROCHURE
 CLIENT
PENTABLOCK™

DESIGNED
 JG
 DRAWN
 JG
 CHECKED
 JG
 APPROVED
 JG

DRAWING
160 PENTABLOCK GATE PILLAR
 IF IN DOUBT, THEN ASK
 DATE MARCH '16 SCALE A4 @ 1:100 PROJECT NO. - DWG NO. 2/2 REV. A

PENTABLOCK DESIGN SUMMARY

160 PENTABLOCK RETAINING WALLS				
RETAINING HEIGHT	STARTER BARS	VERTICAL REINFORCEMENT	HORIZONTAL REINFORCEMENT	FOOTING SIZE
450	N12 BARS @ 360 CRS	N12 BARS @ 360 CRS	N12 BARS @ 450 CRS	400 x 300 MIN
600	N12 BARS @ 360 CRS	N12 BARS @ 360 CRS	N12 BARS @ 450 CRS	500 x 300 MIN
750	N12 BARS @ 360 CRS	N12 BARS @ 360 CRS	N12 BARS @ 450 CRS	600 x 300 MIN
900	N12 BARS @ 360 CRS	N12 BARS @ 360 CRS	N12 BARS @ 450 CRS	750 x 300 MIN
1050	N12 BARS @ 360 CRS	N12 BARS @ 360 CRS	N12 BARS @ 450 CRS	900 x 300 MIN
1200	N12 BARS @ 360 CRS	N12 BARS @ 360 CRS	N12 BARS @ 450 CRS	1000 x 300 MIN
1350	N12 BARS @ 360 CRS	N12 BARS @ 360 CRS	N12 BARS @ 450 CRS	1150 x 300 MIN

190 PENTABLOCK RETAINING WALLS				
RETAINING HEIGHT	STARTER BARS	VERTICAL REINFORCEMENT	HORIZONTAL REINFORCEMENT	FOOTING WIDTH
1400	N12 BARS @ 360 CRS	N12 BARS @ 360 CRS	N12 BARS @ 450 CRS	1100 x 300 MIN
1600	N12 BARS @ 180 CRS	N12 BARS @ 360 CRS	N12 BARS @ 450 CRS	1300 x 300 MIN
1800	N12 BARS @ 180 CRS	N12 BARS @ 360 CRS	N12 BARS @ 450 CRS	1400 x 300 MIN

2500 HIGH 160 PENTABLOCK GATE PILLAR DESIGN - 200 KG GATE - 4.5m SINGLE OPENING					
PILLAR HEIGHT	GATE POROSITY (%)	STARTER BARS	VERTICAL REINFORCEMENT	HORIZONTAL REINFORCEMENT	FOOTING SIZE
2500	50 (SOLID)	5/N16 BARS	5/N16 BARS	N12 BARS @ 450 CRS	1700 x 1700 x 400 MIN
2500	75 (SOLID)	5/N16 BARS	5/N16 BARS	N12 BARS @ 450 CRS	1800 x 1800 x 400 MIN

160 PENTABLOCK FENCE WALL DESIGN				
FENCE HEIGHT	STARTER BARS	VERTICAL REINFORCEMENT	HORIZONTAL REINFORCEMENT	FOOTING SIZE
1200	N12 BARS @ 360 CRS	N12 BARS @ 360 CRS	N12 BARS @ 450 CRS	500 x 400 MIN
1500	N12 BARS @ 360 CRS	N12 BARS @ 360 CRS	N12 BARS @ 450 CRS	600 x 400 MIN
1800	N12 BARS @ 360 CRS	N12 BARS @ 360 CRS	N12 BARS @ 450 CRS	700 x 400 MIN
2100	N12 BARS @ 360 CRS	N12 BARS @ 360 CRS	N12 BARS @ 450 CRS	800 x 400 MIN

2100 HIGH 160 PENTABLOCK FENCE PILLAR DESIGN				
PILLAR HEIGHT	STARTER BARS	VERTICAL REINFORCEMENT	HORIZONTAL REINFORCEMENT	FOOTING SIZE
2100	4/N16 BARS	4/N16 BARS	N12 BARS @ 450 CRS	800 x 800 x 400 MIN

160 WIDE PENTABLOCK FIRE RATING				
WIDTH	STRUCTURAL ADEQUACY	INTEGRITY	INSULATION	RESISTANCE PERIOD
160	OK (T.B.C)	OK	OK	180 MINS
190	OK (T.B.C)	OK	OK	240 MINS

